

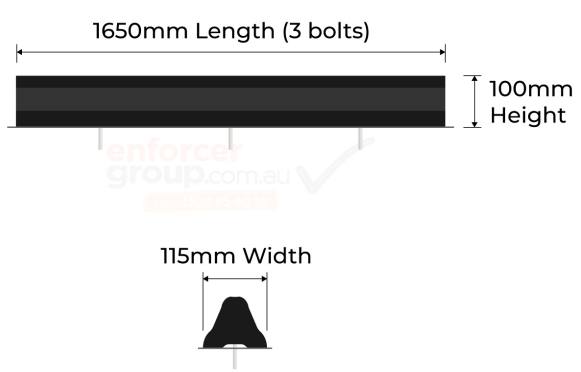

# PRODUCT SPECS



<b>Product Code:</b>	WS-RW-B
<b>Length:</b>	1650mm
<b>Height:</b>	100mm
<b>Width:</b>	115mm
<b>Weight:</b>	11Kg
<b>Colours:</b>	Black
<b>Fixing:</b>	3 Fixings. 12mm x 130mm Sleeve Anchor Bolts for Concrete, or 14mm x 300mm Spikes for Asphalt.



# BLACK RAILWAY WHEEL STOP

- Manufactured from Recycled Plastic and weighs only 11kg.
- Australian Standards Approved
- Light weight easy to install by one person
- Replaces concrete wheel stops that cracks and chips off
- Fixing Bolts Included (Concrete or Asphalt)
- Installation Service is available

Enforcer Recycled Plastic Wheel Stop comply to AS/NZS 2890.1:2004 Environmentally friendly Manufactured from Recycled Plastic and weighs only 11kg.

One piece moulded Very easy to install, designed to be Strong and durable Tough and Solid construction, Unique patented shape for Enforcer Group only.

Suited to use in Concrete or Asphalt for Factories, Warehouses and all Indoor and outdoor Car parks.



Strong & Durable



Australian Standards Approved



Easy Installation

