

# PRODUCT SPECS

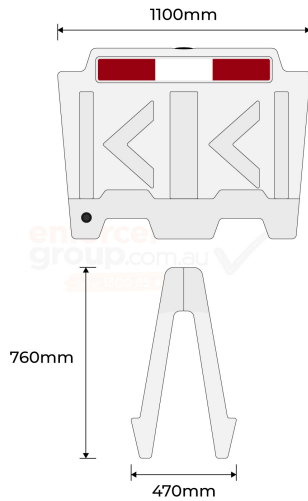

<b>Product Code:</b>	<b>WB-W</b>
<b>Length:</b>	1100mm
<b>Width:</b>	470mm Bottom 100mm Top
<b>Height:</b>	760mm
<b>Weight:</b>	7kg
<b>Water filled Weight:</b>	50Kg
<b>Finish:</b>	White



## WATER FILLED BARRIER - WHITE

- Water filled barrier ensures safety in urban and construction environments
- The product is compact, can easily be stacked and stored
- Engineered to withstand Australian weather and environmental conditions
- Can be filled to 50kg for stability and effective water containment

The Water Filled Barrier – White is not just a static barricading solution; it's adaptable to your needs. It can be filled to a substantial weight of 50kg when needed, which provides stability.

Its lightweight empty state makes it easy to transport and manoeuvre. Installation is straightforward, and it can be quickly filled and deployed to meet specific requirements. Whether you need to delineate construction sites, manage traffic flow, secure events, or protect sensitive areas, the Water Filled Barrier – White is your go-to product.

With its exceptional adaptability and reliability, it's the perfect solution for your safety and security requirements.



Fill Cap



Drain Plug



Inter-locking pegs



Strong & Durable



Australian Standards Approved



Easy Installation

**enforcer**  
**group.com.au**

Call us 1300 85 40 10