



Traffic Lane Kerb Separator - New TLKS-N

Description

The Traffic Lane Kerb Separators are a durable and effective solution for separating lanes of traffic and directing the flow of vehicles. They are designed in a modular fashion, allowing them to be easily installed and configured to fit the layout of any road.

Features

- Modular design allows for easy installation and configuration.
- High visible reflective striping for visibility in poor condition.
- Separates lanes of traffics and directs the flow of vehicles.
- Improves traffic safety and efficiency.

Specifications

Middle Section

SKU	TLKS-M-Black-N TLKS-M-Yellow-N
Length	990 mm
Width	240 mm
Height	85 mm
Weight	15 kg
Material	Rubber

End Section

SKU	TLKS-EP-Black-N TLKS-EP-Yellow-N
Length	500 mm
Width	240 mm
Height	85 mm
Weight	13.5 kg
Finish	Yellow/Black section with White Reflective Panels

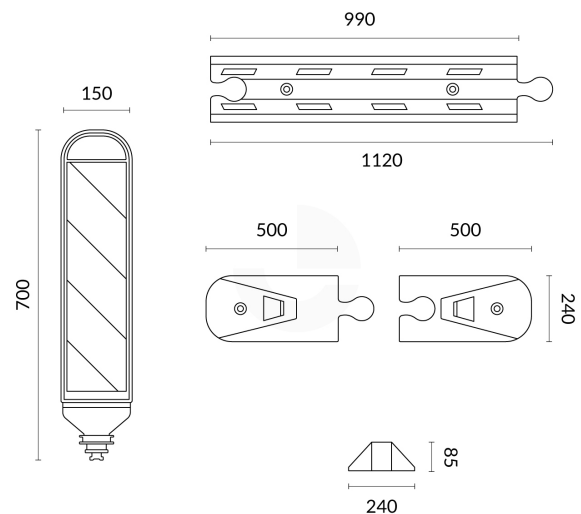
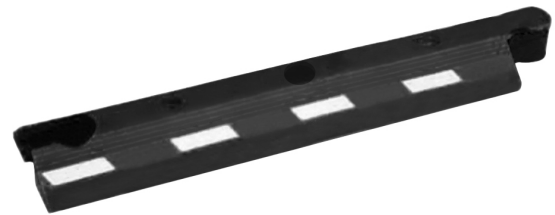



Traffic Lane Kerb Separator TLKS

Specifications

Panel Blade

SKU	TLKS-PBO-N
Width	150 mm
Thickness	50 mm
Height	700 mm
Weight	1 kg
Material	Polyethylene
Finish	Orange blades with reflective panels

