

PRODUCT SPECS

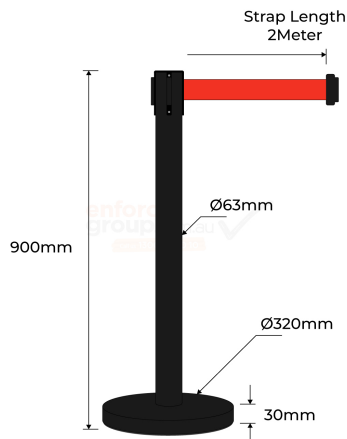

Product Code: RB-PB-R

Diameter: 63mm

Height: 900mm

Base Diameter: 320mm

Weight: 6kg

Strap Length: 2 Metres

Belt: Nylon Red Belt

Fixings: Interlocking Clips, No Fixings Required

Finish: Powder coated matt black



RETRACTABLE BELT BARRIER - POWDER COATED BLACK - RED

- Powder-Coated Steel with A Matt Black Finish
- High Quality Two (2) Metre Nylon Belt
- Durable Self-Locking Clips, features 4-Way Connectivity
- Suited to Use for Crowded Management in Shopping Centres, Hotels, Trade Shows
- Easy to Install, No Fixings or Tools Required

Enforcer Retractable Belt Barrier Bollard is designed for Australian conditions, environmentally friendly manufactured from steel pipe, and 100% recyclable.

Powder-coated steel with a matt black finish. High-quality two (2) metre nylon belt, durable self-locking clips, features 4-way connectivity.

Easy to install or relocate, designed to be strong and durable, no fixings or tools are required, the product comes with a base, post (includes the belt), and cover for the base.

Suited to use for crowded management, guidance, and direction, in shopping centres, hotels, trade shows, and all retail environments.



Strong &
Durable



Australia
Standards
Approved



Easy
Installation

enforcer
group.com.au

Call us **1300 85 40 10**