

PRODUCT SPECS

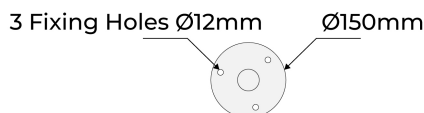
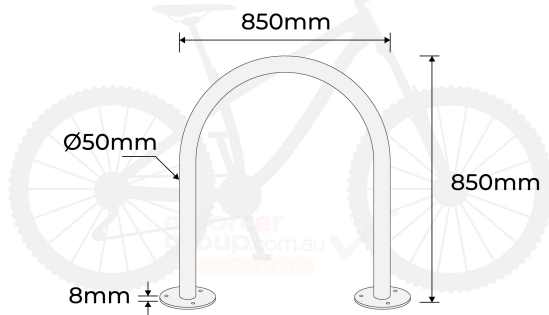

Product Code: BR-SM-G

Diameter: 50mm

Height: 850mm

Width: 850mm

Wall Thickness: 3mm

Weight: 11kg

Finish: Galvanised

Base Plate: 150mm diameter x 8mm thick, 12mm mounting holes



2 Year
Manufacturing
Warranty

Installation
Service
available

www.enforcergroup.com.au



BIKE RACK GALVANISED SURFACE MOUNTED HOOP

- Manufactured from heavy duty steel pipe
- Suitable for public and private areas
- Designed in Australia for Australian conditions
- Weatherproof, safe and secure.
- Installation service is available

Manufactured from heavy duty steel pipe. Designed in Australia for Australian conditions, for indoor or outdoor use.

Enforcer Groups bike racks are built to last. They are weatherproof, safe and secure. The absence of designated bike parking can create issues that may discourage cyclists from visiting in the future. Offering a safe, secure, accessible and easy-to-use bike parking solution to cyclists will ensure a bike friendly environment. More parking space for bikes - more customers coming in.

Suited to use in indoor or outdoor car parks, like shopping centres or libraries, it can be used in public and private areas for bike parking.



Strong &
Durable



Australian
Standards
Approved



Easy
Installation

enforcer
group.com.au

Call us 1300 85 40 10

Address: 57-67 Popes Rd Keysborough Vic 3173 P.O. Box 3076 Ripponlea VIC 3185
Email: Sales@enforcergroup.com.au Phone: 1300 85 40 10