

# PRODUCT SPECS

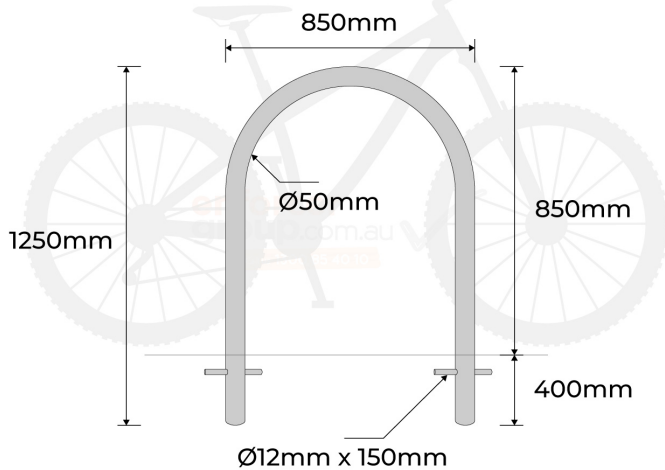

**Product Code:** BR-IG-SS304

**Diameter:** 50mm

**Height:** 850mm above ground plus 400mm in-ground(1250mm)

**Width:** 850mm

**Wall Thickness:** 3mm

**Weight:** 10kg

**Anchor Rod:** 12mmx150mm

**Finished:** Silver Brushed and polished Stainless Steel



**2 Year**  
Manufacturing  
Warranty

Installation  
Service  
available

[www.enforcergroup.com.au](http://www.enforcergroup.com.au)



## IN-GROUND BIKE RACK STAINLESS STEEL HOOP - 304 GRADE

- Manufactured from heavy duty steel pipe
- Silver brushed grade 304 stainless steel
- Suitable for public and private areas
- Designed in Australia for Australian conditions
- Weatherproof, safe and secure.
- Installation service is available

Manufactured from heavy duty steel pipe, silver brushed grade 304 Stainless Steel. Designed in Australia for Australian conditions, for indoor or outdoor use.

Enforcer Groups bike racks are built to last. They are weatherproof, safe and secure. The absence of designated bike parking can create issues that may discourage cyclists from visiting in the future. Offering a safe, secure, accessible and easy-to-use bike parking solution to cyclists will ensure a bike friendly environment. More parking space for bikes - more customers coming in.

Suited to use in indoor or outdoor car parks, like shopping centres or libraries, it can be used in public and private areas for bike parking.



Strong &  
Durable



Australian  
Standards  
Approved



Easy  
Installation

**enforcer**  
**group.com.au**

Call us 1300 85 40 10

Address: 57-67 Popes Rd Keysborough Vic 3173 P.O. Box 3076 Ripponlea VIC 3185  
Email: [Sales@enforcergroup.com.au](mailto:Sales@enforcergroup.com.au) Phone: 1300 85 40 10