

PRODUCT SPECS

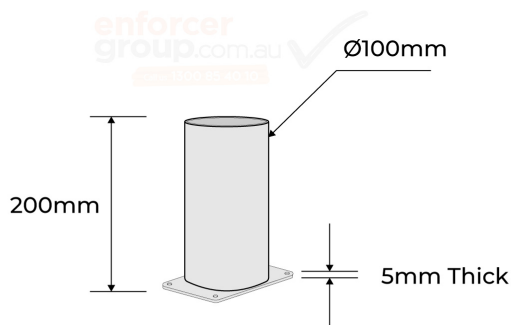
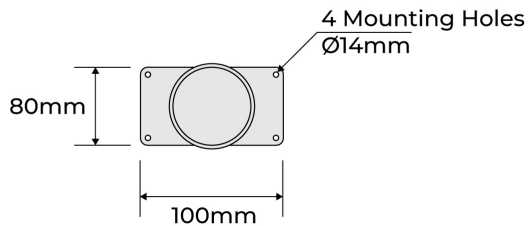

Product Code: B90-SM-REM-BASE

Diameter: 100mm

Height: 200mm

Weight: 2kg

Wall Thickness: 4mm

Base plate: 100mm x 80mm, 5mm thick, 4 mounting holes 14mm diameter

Finish: Silver galvanized



BOLLARD BASE ONLY 90MM SURFACE MOUNTED REMOVABLE - GALVANISED

- Manufactured from heavy duty Steel Pipe
- Hot Dipped Galvanised Steel for rust prevention
- Withstands from heavy cars, trucks, and forklifts
- Designed in Australia for Australian Conditions
- Installation Service is available

Enforcer Galvanised Sleeves are designed in Australia for Australian Conditions, Environmentally friendly Manufactured from Steel Pipe, and 100% Recyclable. Hot Dipped Galvanised Steel for rust prevention.

Storage Sleeves are specially designed to store your bollard safely and efficiently.

Helps to prevent unwanted damage and reduces the risk of bollards being a trip hazard for pedestrians when they are removed and not in use.

Suited to use in Concrete to keep the bollard safe when not in use for all Warehouses, Car Parks, Driveways.



Strong &
Durable



Australian
Standards
Approved



Easy
Installation

enforcer
group.com.au

Call us 1300 85 40 10