

PRODUCT SPECS

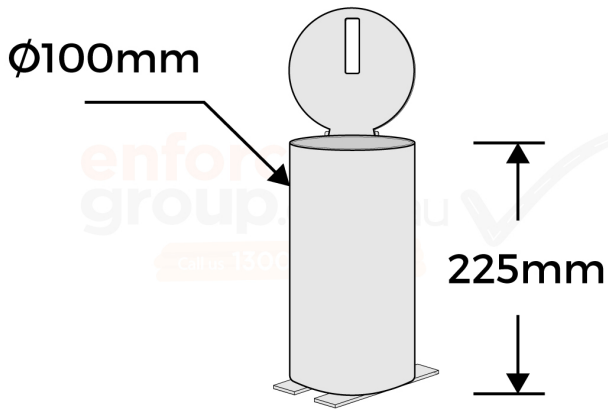

Product Code:	B90-IG-REM-BASE
Diameter:	100mm (130mm inc. hinge)
Height:	225mm in-ground
Weight:	2kg
Wall Thickness:	4mm
Finish:	Silver galvanized



BOLLARD 90MM IN-GROUND REMOVABLE BASE

- Manufactured from heavy duty Steel Pipe
- Hot Dipped Galvanised Steel for rust prevention
- Withstands from heavy cars, trucks, and forklifts
- Designed in Australia for Australian Conditions
- Installation Service is available

Enforcer Galvanised Sleeves are designed in Australia for Australian Conditions, Environmentally friendly Manufactured from Steel Pipe, and 100% Recyclable. Hot Dipped Galvanised Steel for rust prevention.

Storage Sleeves are specially designed to store your bollard safely and efficiently. Helps to prevent unwanted damage and reduces the risk of bollards being a trip hazard for pedestrians when they are removed and not in use.

Suited to use in Concrete or asphalt to keep the bollard safe when not in use for all Warehouses, Car Parks, Driveways.



Strong & Durable



Australian Standards Approved



Easy Installation

enforcer
group.com.au

Call us 1300 85 40 10