

PRODUCT SPECS

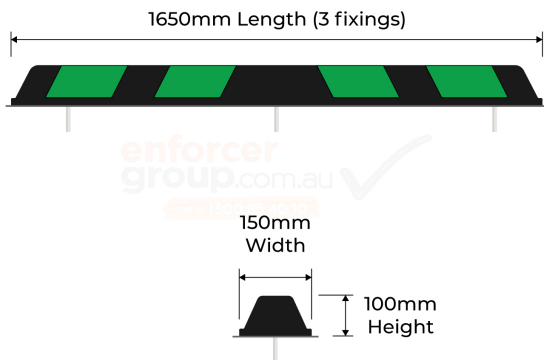

Product Code: **WS-EV-Enforcer**

Length: 1650mm

Height: 100mm

Width: 150mm

Weight: 14Kg

Colours: Solid Black with Green Reflective Panels

Fixing: 3 Fixings.
14mm x 150mm Dyna Bolts for Concrete or 14mm x 300mm Spikes for Asphalt



5 Year
Manufacturing
Warranty

Installation
Service
available



THE ENFORCER-EV WHEEL STOP

- Manufactured from 100% Recycled Plastic
- Useful for EV parking and EV charging space
- Australian Standards Approved
- 5 Year manufacturing warranty
- Most durable Wheel Stop on the market
- Fixing Bolts Included (Concrete or Asphalt)
- Installation Service is available

The "ENFORCER" EV Wheel Stop Complies to AS/ NZS 2890.1:2004. It is environmentally friendly and manufactured from 100% Recycled Plastic.

It is one piece moulded, very easy to install and has green reflective panels on either side to increase night time visibility. It is a heavy duty product which won't fade, chip or crack. And comes with a guaranteed 5-year manufacturing warranty.

Suited to use in Concrete or Asphalt surface for Factories, Schools, Hospitals, Airports, Warehouses, and all Indoor or outdoor Car parks which has separate EV parking/charging space.



Strong &
Durable



Australian
Standards
Approved



Easy
Installation

enforcer
group.com.au

Call us **1300 85 40 10**